

PLEASE COMPLETE AS MUCH AND AS ACCURATELY AS POSSIBLE.
CUSTOMER INFORMATION

Name :	
Name of the company :	
Email:	
Phone:	
Address:	

City :	
State :	
Country :	
ZIP:	

SHIP INFORMATION

Name of the ship :	
Type of the ship :	
Total length (m) :	
Length at waterline (m) :	
Beam (m):	
Draft (m):	
Number of engines :	
Continuous HP power:	
rpm (continuous):	
Reduction ratio :	
Type of propeller :	
Ø tail shaft (mm):	
Commentaries :	

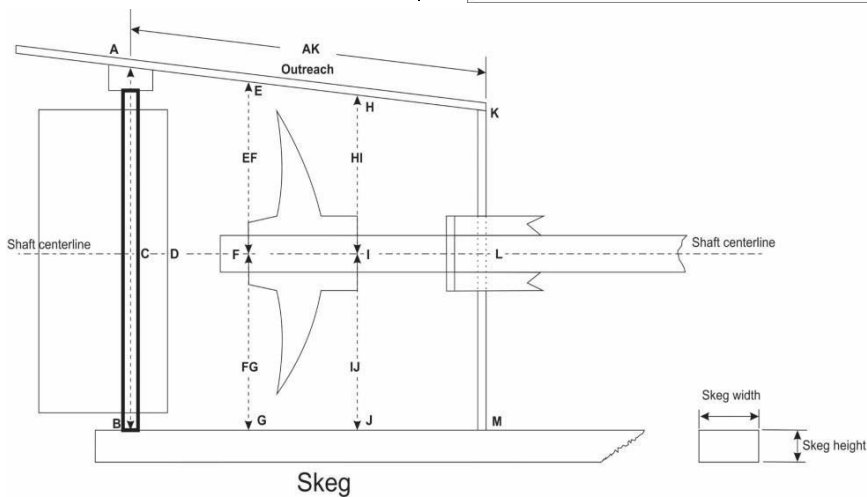
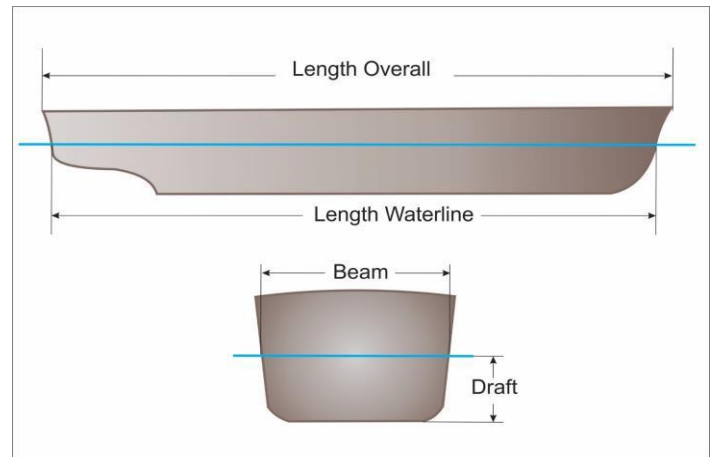

Shaft centerline:	LI _____	IF _____	FD _____	DC _____		
Aft frame :	LK _____	LM _____				
Hub-Fwd End :	HI _____	IJ _____				
Hub-Aft End :	EF _____	FG _____				
Rudder :	AB _____					
Skeg & Outreach :	BM _____	AK _____	BJ _____	AH _____		
Details of propeller:	Diam. _____	Pitch _____	Z _____	EAR _____	Rotation _____	Ø of shaft _____
Free space :	Blade tip to outreach _____		Blade tip to skeg _____			